

### CLAMP ASSEMBLY

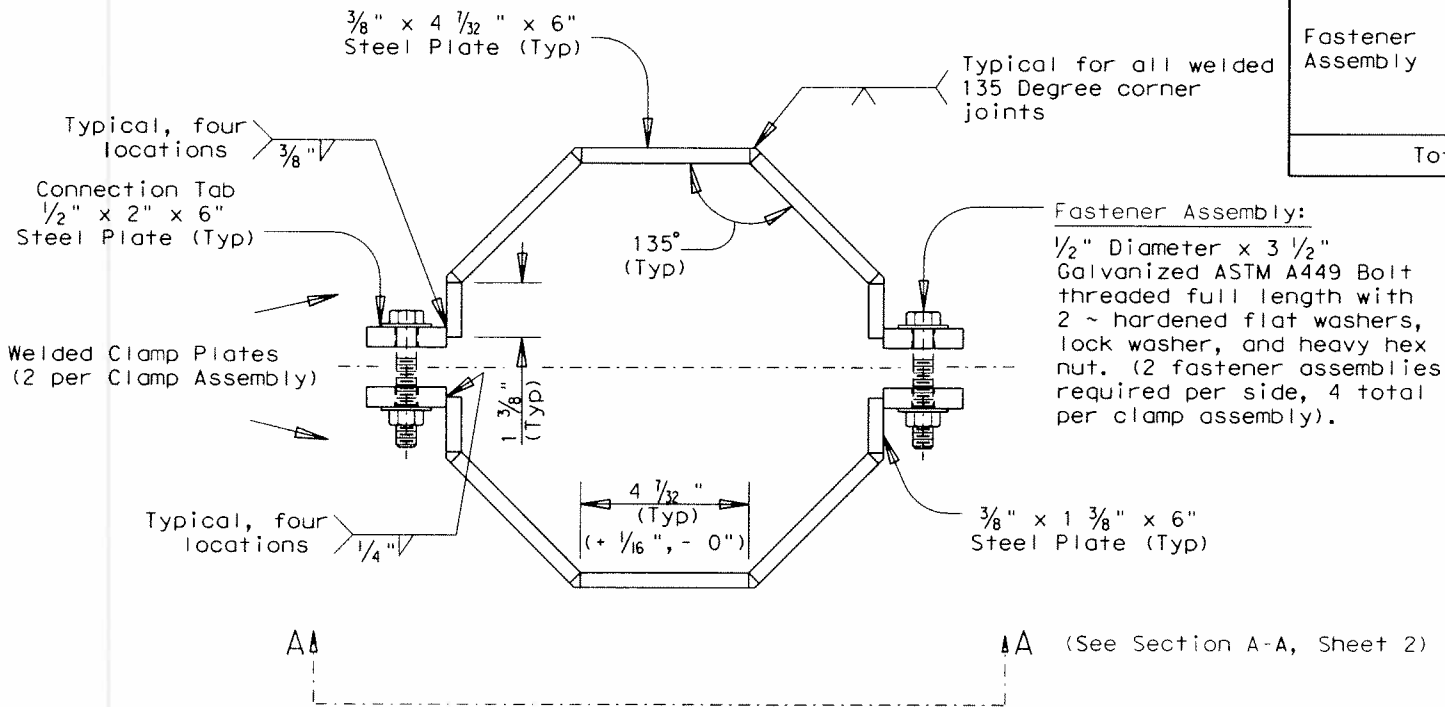

### Sleeve Repair Clamp Assembly

Item	* Quantity	* Weight (approx.)
Clamp Plate (Bent or Welded)	2	27 lbs
Fastener Assembly	4	1.5 lbs
Total Weight		28.5 lbs

\* Per Clamp Assembly

Fastener Assembly:  
 1/2" Diameter x 3 1/2" Galvanized ASTM A449 Bolt threaded full length with 2 ~ hardened flat washers, lock washer, and heavy hex nut. (2 fastener assemblies required per side, 4 total per clamp assembly).

See General Notes, Sheet 2, for bent clamp plate option.

Sheet 1 of 2

Texas Department of Transportation  
 Austin District  
**Signal Mast Arm Sleeve  
 Repair Clamp**

FILED	DATE	BY	CHKD	APP'D	CR.
10/1/00					
REVISIONS					
	6				
	COUNTY	CONTROL	SECT	JOB	HIGHWAY

LEVELS DISAPPEAR PA TH

# CLAMP ASSEMBLY

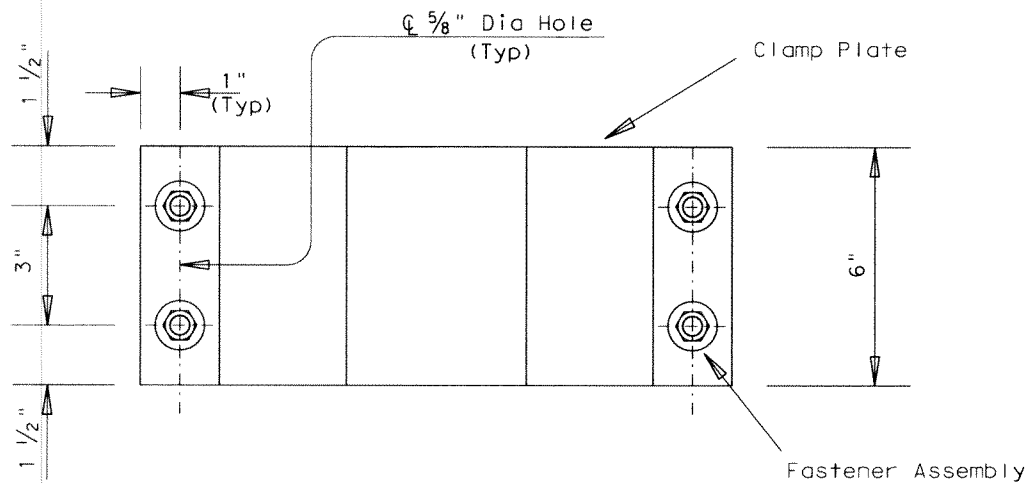

# SECTION A-A

## GENERAL NOTES:

A minimum of 40% of the welds shall undergo Nondestructive Examination (NDE) per Item 441.5 at the contractor's expense.

Plate Clamp Assembly to be hot dipped galvanized per Item 445 after fabrication.

All Steel shall be ASTM A36 meeting or exceeding the requirements per Item 442, Metal for Non-Bridge Structures.

Contractor may utilize a bent plate option, substituting 3/8" plate in lieu of the 1/2" plate connection tabs detailed. If this option is used, tolerances specified must be maintained.

All bolts shall be ASTM A449, fully threaded, galvanized, coarse thread bolts. Heavy hex nuts, hardened flat washers, and lock washers shall be galvanized.

SCALE: 1/8" = 1'-0"  
 1 2 3 4 5 6 7 8 9 10 11 12 13 14 15 16 17 18 19 20 21 22 23 24 25 26 27 28 29 30 31 32 33 34 35 36 37 38 39 40 41 42 43 44 45 46 47 48 49 50 51 52 53 54 55 56 57 58 59 60 61 62 63 64 65 66 67 68 69 70 71 72 73 74 75 76 77 78 79 80 81 82 83 84 85 86 87 88 89 90 91 92 93 94 95 96 97 98 99 100  
 PATH:

Sheet 2 of 2

Texas Department of Transportation  
 Austin District

Signal Mast Arm Sleeve  
 Repair Clamp

FILE#	DN	CR	DN	CR
TxDOT	DIST	FED REC	FEDERAL AID PROJECT	SHEET
REVISIONS	6			
COUNTY	CONTRACT	SECT	JOB	HIGHWAY