

**ASPHALT IN-HOUSE CALIBRATION PROCEDURE # 10
PYCNOMETER FOR SPECIFIC GRAVITY OF SEMI-SOLID BITUMINOUS MATERIAL**

EQUIPMENT CHECKED: PYCNOMETER FOR SPECIFIC GRAVITY OF SEMI-SOLID BITUMINOUS MATERIAL (AASHTO T 228) (ASTM D 70)

1. SCOPE

1.1 This procedure provides instructions for checking the critical dimensions of a pycnometer use to perform the specific gravity test.

2. APPARATUS

Inspection Equipment Required:

1. Caliper, readable to 0.001 in.
2. Balance, readable to 0.001 g
3. Graduated cylinder, readable to 1.0 ml

Tolerance:

Equipment shall meet the tolerances specified in test methods T 228 and D 70.

3. PROCEDURE

- 3.1 Fill a clean pycnometer with water. Position stopper atop the pycnometer and remove excess water as described in test method T 228 and D 70. Remove the stopper from the pycnometer being careful not to spill the water. With the aid of a small funnel, pour the contents of the pycnometer into a graduated cylinder. Measure and record the results to the nearest 1.0 ml.
- 3.2 Using a balance, readable to 0.001 g., weigh and record, to the nearest 1 mm., the weight of the pycnometer and stopper.
- 3.3 Using a caliper, readable to 0.001 inches, measure and record to the nearest 1 mm. the diameter of the stopper.

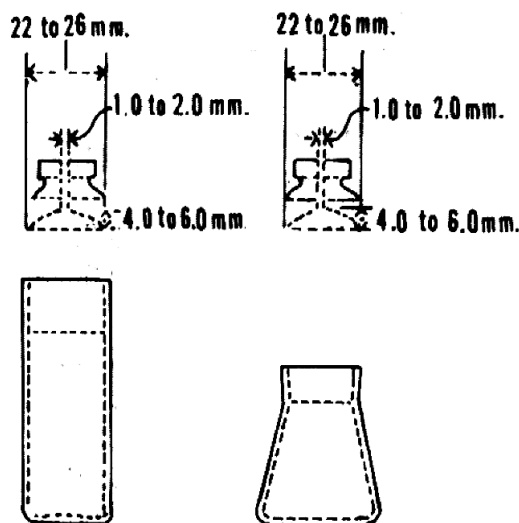

(a) Pycnometers

ASPHALT IN-HOUSE CALIBRATION PROCEDURE # 10
PYCNOMETER FOR SPECIFIC GRAVITY OF SEMI-SOLID BITUMINOUS MATERIAL

- 3.4 Measure and record, to the nearest 1 mm., the diameter of the small hole in the stopper.
- 3.5 Following the illustration in test method T228 and D 70 use a caliper to measure the height of the concavity at the bottom of the stopper. Record result. If the stopper is not concave, record to 0.0.
- 3.6 Finally, inspect the physical condition of the pycnometer and stopper. The stopper should be free of any chips along the edge of the bottom or along the edge of the hole. Record any chips.

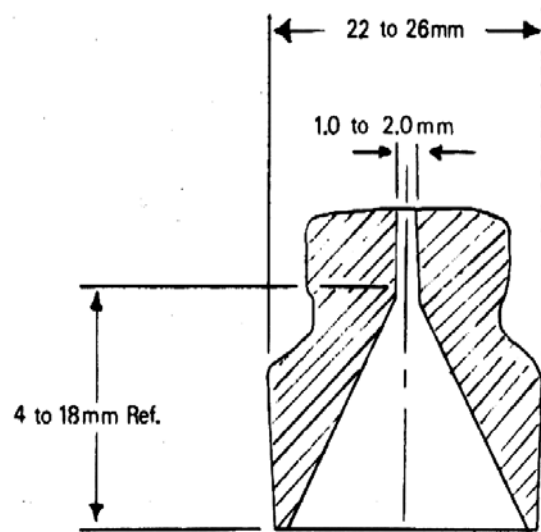

(b) Stopper